

# ***Energizer***®



**CHARGER**  
**EZ40VCH**  
**EZ40VCH-UK**

**USER GUIDE**

CAUTION: Read this manual before using this machine!

# ***Energizer***®

©2023 Energizer. Energizer and certain graphic designs are trademarks of Energizer Brands, LLC and related subsidiaries and are used under license by Builder SAS. All other brand names are trademarks of their respective owners. Neither Builder SAS nor Energizer Brands, LLC is affiliated with the respective owners of their trademarks.

**Let's get started.**

You're excited to power up, so we'll keep this brief!

# CONTENTS

1. SAFETY INSTRUCTIONS.....	5
2. SPECIFIED CONDITIONS OF USE.....	8
3. SYMBOLS.....	9
4. YOUR PRODUCT.....	9
5. OPERATION.....	10
6. MAINTENANCE.....	11
7. CLEANING THE CHARGER.....	11
8. STORAGE.....	12
9. LED FUNCTIONS.....	12
10. DISPOSAL.....	12
11. WARRANTY.....	13
12. PRODUCT FAILURE.....	14
13. WARRANTY EXCLUSIONS.....	15

# 1. SAFETY INSTRUCTIONS

READ AND FOLLOW ALL IMPORTANT SAFETY INSTRUCTIONS.

When using electrical products, basic precautions should always be practiced including the following.

- Read and follow all instructions that are on the product or provided with product.
- For a cord-connected unit, do not use an extension cord.
- Reference the national electrical code, ANSI/NFPA70, specifically for the installation of wiring and clearances from power and lighting conductors.
- Installation and electrical wiring must be done by qualified person(s) in accordance with all applicable codes and standards, including fire-rated construction.
- For a cord-connected unit, do not install or use within 10 feet or a pool.
- For a cord-connected unit, do not use in a bathroom.

**SAVE THESE INSTRUCTIONS:** this manual contains important safety and operating instructions for power units.

 **WARNING!** Read all safety warnings and all instructions. Failure to follow the warnings and instructions may result in electric shock, fire and serious injury.

- Save all warnings and instructions for future reference.
- This appliance cannot be used by children aged from

8 years and above if they are continuously supervised.

- This appliance cannot be used by people with reduced physical, sensory or mental capabilities or lack of experience and knowledge if they have been given supervision or instruction concerning use of the appliance in a safe way and understand the hazards involved.

- Children shall not play with the appliance.

- Cleaning and user maintenance shall not be made by children without supervision.

 **WARNING!** When using the battery charger, the following basic safety precautions should be observed for protection against electric shock, danger of injury, and burns.

- Please read and observe these instructions before using the device.

- Only the following battery packs can be charged with this charger: EZ40VBA4.

- This charger is only to be used indoor under dry conditions.

- This charger is not intended to charge any other type of battery and should never be used in explosive or inflammable environments.

- Non-rechargeable batteries cannot be charged with this battery charger.

- To protect against the risk of electrical shock, do not immerse the unit, cord or plug in water or other liquid.

- Before using the device check that the mains cable and mains plug are not damaged.
- The device must not be damp, and it should not be used in a damp environment.
- Do not use the device if it has suffered any heavy shock or jolting, or has been damaged in any other way.
- Due to the heat generated during charging, the battery charger should not be operated on a combustible surface or in an inflammable environment.
- Do not cover the ventilating slits.
- Never disassemble the device yourself. Danger of an electric shock or fire could be caused by improper reassembly.
- When the appliance is not in use and before cleaning and maintenance, unplug the appliance from the outlet.
- During charging, the battery pack with charger must be placed in a well-ventilated area. Malfunction during charging can be caused by storing and operating in places where the temperature exceeds +40°C, this should be avoided. Battery charging in closed cupboards, near heat sources (radiators, bright sunshine) etc., causes heat to accumulate and can damage the device.
- If the battery is not going to be used for a longer period, pull the battery off the battery charger and disconnect the mains plug.
- Protect battery contacts to avoid a short circuit caused

by a metallic object that can cause a fire or explosion.

- Do not rivet or screw any name-plates or signs onto the device. The protective insulation can thereby be rendered ineffective. Adhesive labels are recommended.
- If the mains cord is damaged, it must be replaced by the manufacturer, its service agent, or similarly qualified persons in order to avoid a hazard.

 **WARNING!** Do not insert any object into the ventilation slots or charging connector. This can cause damage to the appliance and may increase the risk of personal injury and property damage.

 **WARNING!** Do not alter or modify the unit from the original design or function. This may increase the risk of serious personal injury or property damage.







 **WARNING!** Before you plug in your product, make sure that the supply voltage used corresponds to that indicated on the rating plate.

## 2. SPECIFIED CONDITIONS OF USE

The product is intended only for charging the 36 V Li-Ion battery packs. See TECHNICAL DATA for details. If the supply cord is damaged, it must be replaced by the manufacturer, its service agent or similarly qualified persons in order to avoid a hazard.

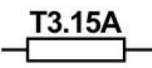

## 3. SYMBOLS

	Safety alert.
	Before charging, read the instructions.
	Regulatory Compliance Mark (RCM). Product meets applicable regulatory requirements.
	<p>Correct Disposal of this product.</p> <p>This marking indicates that this battery charger and battery pack should not be disposed with other household wastes throughout the EU. To prevent possible harm to the environment or human health from uncontrolled waste disposal, recycle it responsibly to promote the sustainable reuse of material resources.</p> <p>To return your used device, please use the return and collection systems or contact the retailer where the product was purchased. They can take this product for environmental safe recycling.</p>
	For indoor use only.
	Class II.
	Waste electrical products should not be disposed of with household waste. Please recycle where facilities exist. Check with your Local Authority or retailer for recycling advice.
	Fuse.

## 4. YOUR PRODUCT

### 4.1 DESCRIPTION

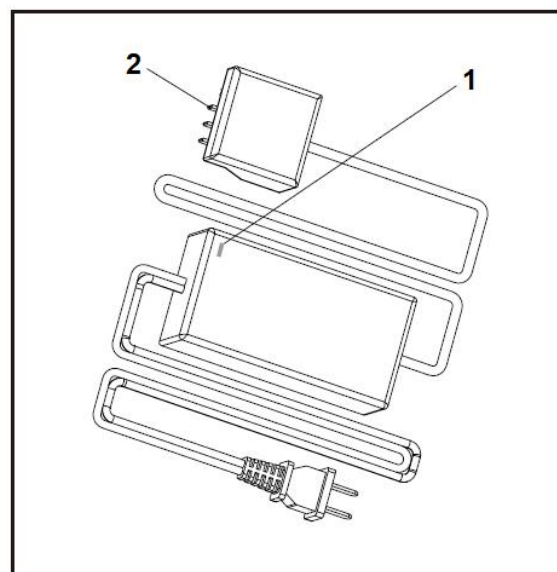

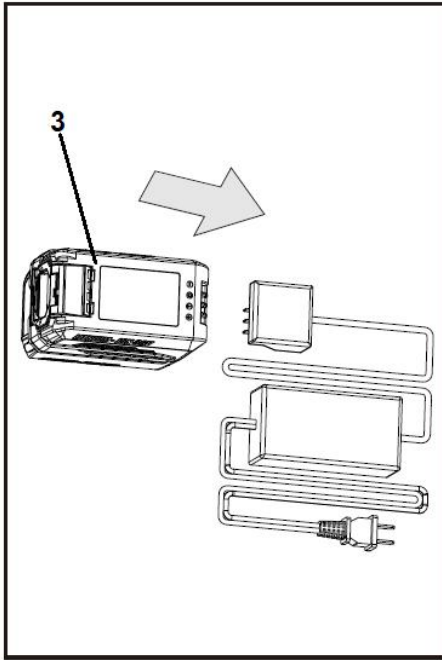

Pull out the battery port when you're finished charging.

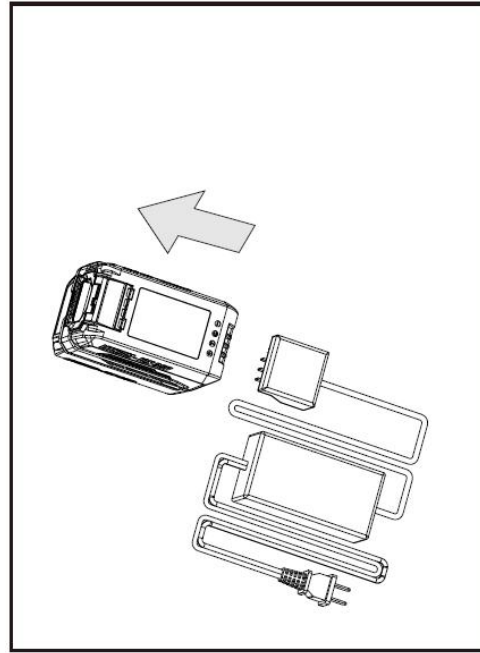

Insert the battery port to start charging.

1. Red LED
2. Battery port
3. Battery pack

## 4.2 TECHNICAL DATA

Input	100-240VAC 50/60Hz 1.8A
Output	36V d.c. 1.8A
Charger battery	Li-ion
Insulation class	Class II

## 5. OPERATION

**⚠ WARNING! Do not allow familiarity with products to make you careless.** Remember that a careless fraction of a second is sufficient to inflict serious injury.

**⚠ WARNING! Do not use any attachments or accessories not recommended by the manufacturer of this product.** The use of attachments or accessories not recommended can result in serious personal injury.

**⚠ WARNING! Never operate the charger where there is a possibility of inflammable or explosive gases or vapor.** Keep well away from petroleum, paint and cleaning supplies, and gas-fired heating systems.

**⚠ WARNING! Charge in a well-ventilated area.** Do not block charger vents. Keep them clear to allow proper ventilation.

### CHARGING THE BATTERY PACK

Battery packs are shipped in a low charge condition to prevent possible problems. Therefore, you should charge them until the green LED on the front of the charger comes on.

## CHARGING A HOT BATTERY PACK

When using a tool continuously, the batteries in the battery pack will become hot. You should let a hot battery pack cool down for approximately 30 minutes before attempting to recharge.

**NOTE:** This situation only occurs when continuous use of a tool causes the batteries to become hot. It does not occur under normal circumstances. Refer to CHARGING A COOL BATTERY PACK for normal recharging of batteries. If the charger does not charge the battery pack under normal circumstances, return both the battery pack and the charger to your nearest authorized service centre for electrical check.

## CHARGING A COOL BATTERY PACK

Only charge the 36V Li-Ion battery packs with this charger. Make sure the power supply is normal household voltage, 100-240VAC 50/60Hz, AC only. Make sure the battery pack is secured in the charger before beginning operation.

- Connect the charger to the power supply.
- Place the battery pack in the charger, aligning the raised rib on the battery pack with the groove in the charger.
- Slide in the battery pack to be sure contacts on the battery pack engage properly with contacts in the charger.

**NOTE:** After charging is complete, the green charger LED will remain on until the battery pack is removed from the charger or charger is disconnected from the power supply. The battery pack will become slightly warm to the touch while charging. This is normal and does not indicate a problem. Do not place the charger and the battery pack in an area of extreme hot or cold. They will work best at normal room temperature.

**NOTE:** The charger and battery pack should be placed in a location where the temperature is more than 10°C but less than 40°C.

- When batteries become fully charged, unplug the charger from the power supply and remove the battery pack.

## COMPATIBLE BATTERY PACKS

EZ40VBA4: 36V d.c.(max 40V d.c.) 4Ah

## BATTERY PROTECTION FEATURES

36V lithium-ion batteries are designed with features that protect the lithium-ion cells and maximize battery life. If the tool stops during use, release the trigger to reset and resume operation. If the tool still does not work, the battery needs to be recharged.



**WARNING!** If at any point during the charging process none of the LED are lit, remove the battery pack from the charger to avoid damaging the product. Do not insert another battery. Return the charger and battery to your nearest service centre for service or replacement.

# 6. MAINTENANCE

There are no user serviceable parts or adjustments inside the battery or charger. Both should be returned to an authorized service centre for specialized attention.



**WARNING!** Risk of injury. Service, testing and repairs should only be carried out by authorized service centre. We recommend our customer service department or authorized service centers.

# 7. CLEANING THE CHARGER



**WARNING!** Unplug the charger power cord from the power supply before cleaning to prevent serious personal injury.

- Clean the charger surface (except labels) using a damp cloth with a mild detergent.
- Do not use any strong detergents on the plastic housing. They can be damaged by certain aromatic oil

such as pine and lemon, and by solvents such as kerosene.

- Moisture can cause a shock hazard. Wipe off any moisture with a soft dry cloth.
- Use a small brush or the air discharge of a small vacuum cleaner brush to clean the air vents on the charger.
- Keep the air vents free of obstructions.

## 8. STORAGE

Store your charger in a cool dry place between 10°C and 25°C.

It is not recommended to leave it in a vehicle during hot or cold conditions. Ensure no metal filings or chips can fall into the vents during storage, as this may cause serious injury when it is next used.

## 9. LED FUNCTIONS

Mode	Red	Green
Standby power	Off	On
Charging	Off	Flash
Full Charge	Off	On
Too hot too cold	Flash	Flash
Defective	Flash	Off

### **WARNING!**

- Please check prior use, if output voltage and current of the battery charger is suitable for the charging battery pack.
- Disconnect the supply before making or breaking the connections to the battery.
- Cleaning and user maintenance shall not be made by children without supervision.
- If the shape of the plug does not fit the power outlet, use an attachment plug adaptor of the proper configuration for the power outlet

### **MAINTENANCE AND SERVICING**

- The equipment should not be stored in a damp environment or in places with corrosive gases. Store in a dry place outside of the range of children.
- Clean the surface of the equipment and wipe it off only with a dry cloth.
- The equipment may not be dismantled. If the equipment is damaged, contact the supplier or manufacturer.
- Maintenance and servicing are not required under normal conditions.

## 10. DISPOSAL



Electric power tools, as well as their accessories and packaging, must each be able to follow an appropriate recycling pathway. Only for the countries of the European Union.

Do not throw away your electrical appliance with the household waste! In accordance with the European Directive 2012/19/EU on waste electrical and electronic equipment and its implementation in national laws, power tools that can no longer be used must be separated and follow an appropriate recycling pathway.

# 11. WARRANTY



## WARRANTY

The manufacturer guarantees the product against defects in material and workmanship for a period of 2 years from the date of the original purchase. The warranty only applies if the product is for household use. The warranty does not cover breakdowns due to normal wear and tear.

The manufacturer agrees to replace parts identified as defective by the designated distributor. The manufacturer does not accept responsibility for the replacement of the machine, in whole or in part, and/or ensuing damage.

**The warranty does not cover breakdowns due to:**

- insufficient maintenance.
- abnormal assembly, adjustment or operations of the product.
- parts subject to normal wear and tear.

**The warranty does not extend to:**

- shipping and packaging costs.
- using the tool for a purpose other than that for which it was designed.
- the use and maintenance of the machine done in a manner not described in the user manual.

Due to our policy of continuous product improvement, we reserve the right to alter or change specifications without notice. Consequently, the product may be different from the information contained therein, but a modification will be undertaken without notice if it is recognized as an improvement of the preceding characteristic.

### READ THE MANUAL CAREFULLY BEFORE USING THE MACHINE.

When ordering spare parts, please indicate the part number or code, you can find this in the spare parts list in this manual. Keep the purchase receipt; without it, the warranty is invalid. To help you with your product, we invite you to contact us by phone or via our website:

- **+33 (0)9.70.75.30.30**
- **<https://services.swap-europe.com/contact>**

You must create a "ticket" via the web platform.

- Register or create your account.
- Indicate the reference of the tool.
- Choose the subject of your request.
- Describe your problem.
- Attach these files: invoice or sales receipt, photo of the identification plate (serial number), photo of the part you need (for example: pins on the transformer plug which are broken).



# 12. PRODUCT FAILURE

## WHAT TO DO IF MY MACHINE BREAKS DOWN?

### **If you bought your product in a store:**

- a) Empty the fuel tank if your product has one.
- b) Make sure that your machine is complete with all accessories supplied, and clean! If this is not the case, the repairer will refuse the machine.

Go to the store with the complete machine and with the receipt or invoice.

### **If you bought your product on a website:**

- a) Empty the fuel tank if your product has one.
- b) Make sure that your machine is complete with all accessories supplied, and clean! If this is not the case, the repairer will refuse the machine.
- c) Create a SWAP-Europe service ticket on the site: <https://services.swap-europe.com> When making the request on SWAP-Europe, you must attach the invoice and the photo of the nameplate (serial number).
- d) Contact the repair station to make sure it is available before dropping off the machine.

Go to the repair station with the complete machine packed, accompanied by the purchase invoice and the station support sheet downloadable after the service request is completed on the SWAP-Europe site.

For machines with engine failure from manufacturers BRIGGS & STRATTON, HONDA and RATO, please refer to the following instructions.

Repairs will be done by approved engine manufacturers of these manufacturers, see their site:

- <http://www.briggsandstratton.com/eu/fr>
- <http://www.honda-engines-eu.com/fr/service-network-page;jsessionid=5EE8456CF39CD572AA2AEEDFD290CDAE>
- <https://www.rato-europe.com/it/service-network>

**Please keep your original packaging to allow for after-sales service returns or pack your machine with a similar cardboard box of the same dimensions.**

**For any question concerning our after-sales service you can make a request on our website <https://services.swap-europe.com>**

**Our hotline remains available at +33 (9) 70 75 30 30.**



# 13. WARRANTY EXCLUSIONS

## THE WARRANTY DOES NOT COVER:

- Start-up and setting up of the product.
- Damage resulting from normal wear and tear of the product.
- Damage resulting from improper use of the product.
- Damage resulting from assembly or start-up not in accordance with the user manual.
- Breakdowns related to carburetion beyond 90 days and fouling of carburetors.
- Periodic and standard maintenance events.
- Actions of modification and dismantling that directly void the warranty.
- Products whose original authentication marking (brand, serial number) has been degraded, altered or withdrawn.
- Replacement of consumables.
- The use of non-original parts.
- Breakage of parts following impacts or projections.
- Accessories breakdowns.
- Defects and their consequences linked to any external cause.
- Loss of components and loss due to insufficient screwing.
- Cutting components and any damage related to the loosening of parts.
- Overload or overheating.
- Poor power supply quality: faulty voltage, voltage error, etc.
- Damages resulting from the deprivation of enjoyment of the product during the time necessary for repairs and more generally the costs related to the immobilization of the product.
- The costs of a second opinion established by a third party following an estimate by a SWAP-Europe repair station.
- The use of a product which would show a defect or a breakage which was not the subject of an immediate report and/or repair with the services of SWAP-Europe.
- Deterioration linked to transport and storage\*.
- Launchers beyond 90 days.
- Oil, petrol, grease.
- Damages related to the use of non-compliant fuels or lubricants.

\* In accordance with transport legislation, damage related to transport must be declared to carriers within 48 hours maximum after observation by registered letter with acknowledgement of receipt.

This document is a supplement to your notice, a non-exhaustive list.

**Attention:** All orders must be checked in the presence of the delivery person. In case of refusal by the delivery person, you must simply refuse the delivery and notify your refusal.

**Reminder:** The reserves do not exclude the notification by registered letter with acknowledgement within 72 hours.

**Information:** Thermal devices must be wintered each season (service available on the SWAP-Europe site). Batteries must be charged before being stored.

***Energizer***®